

|     |    |      |     |
|-----|----|------|-----|
| LTR | CO | DATE | CHK |
|     |    |      |     |

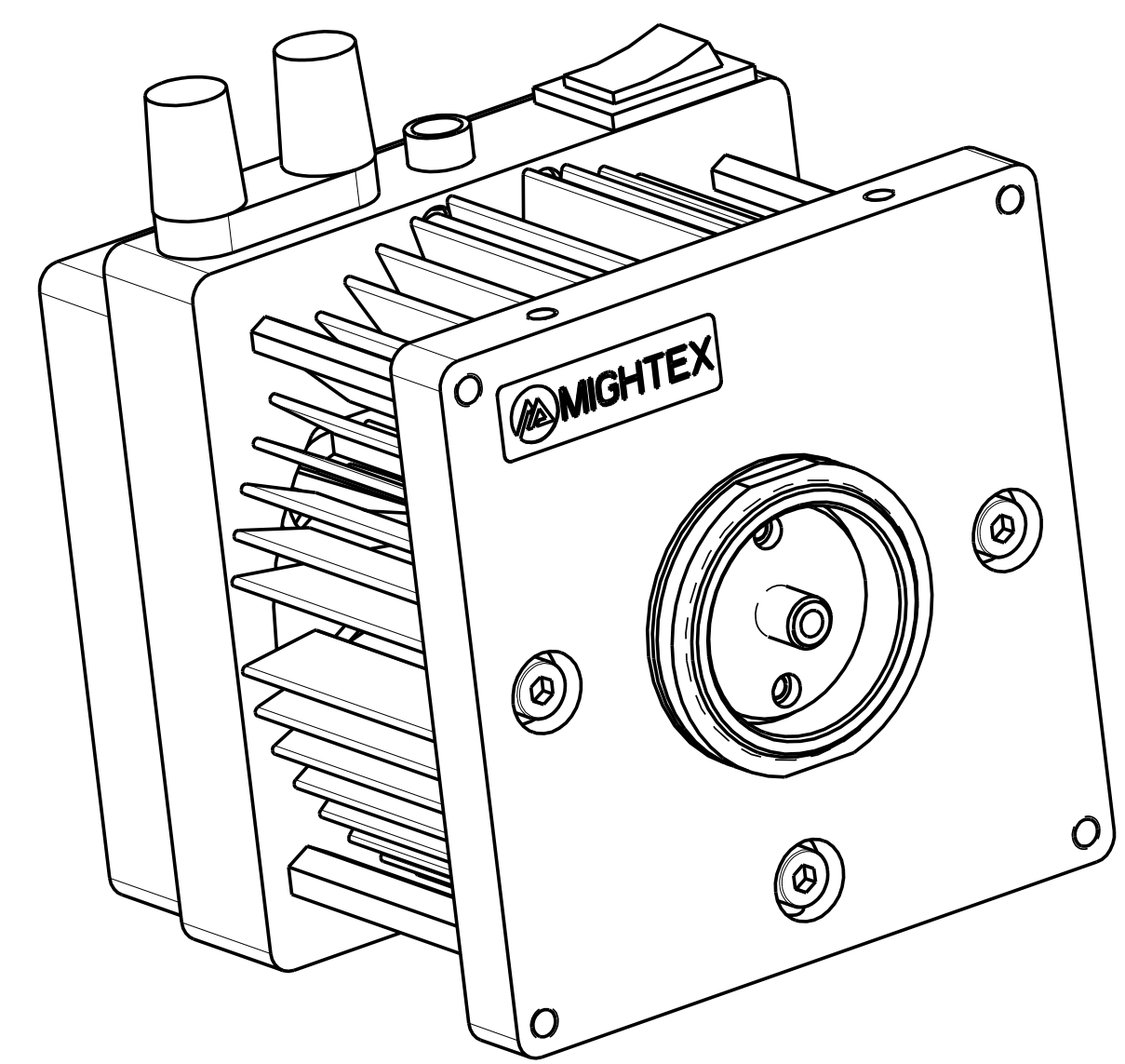
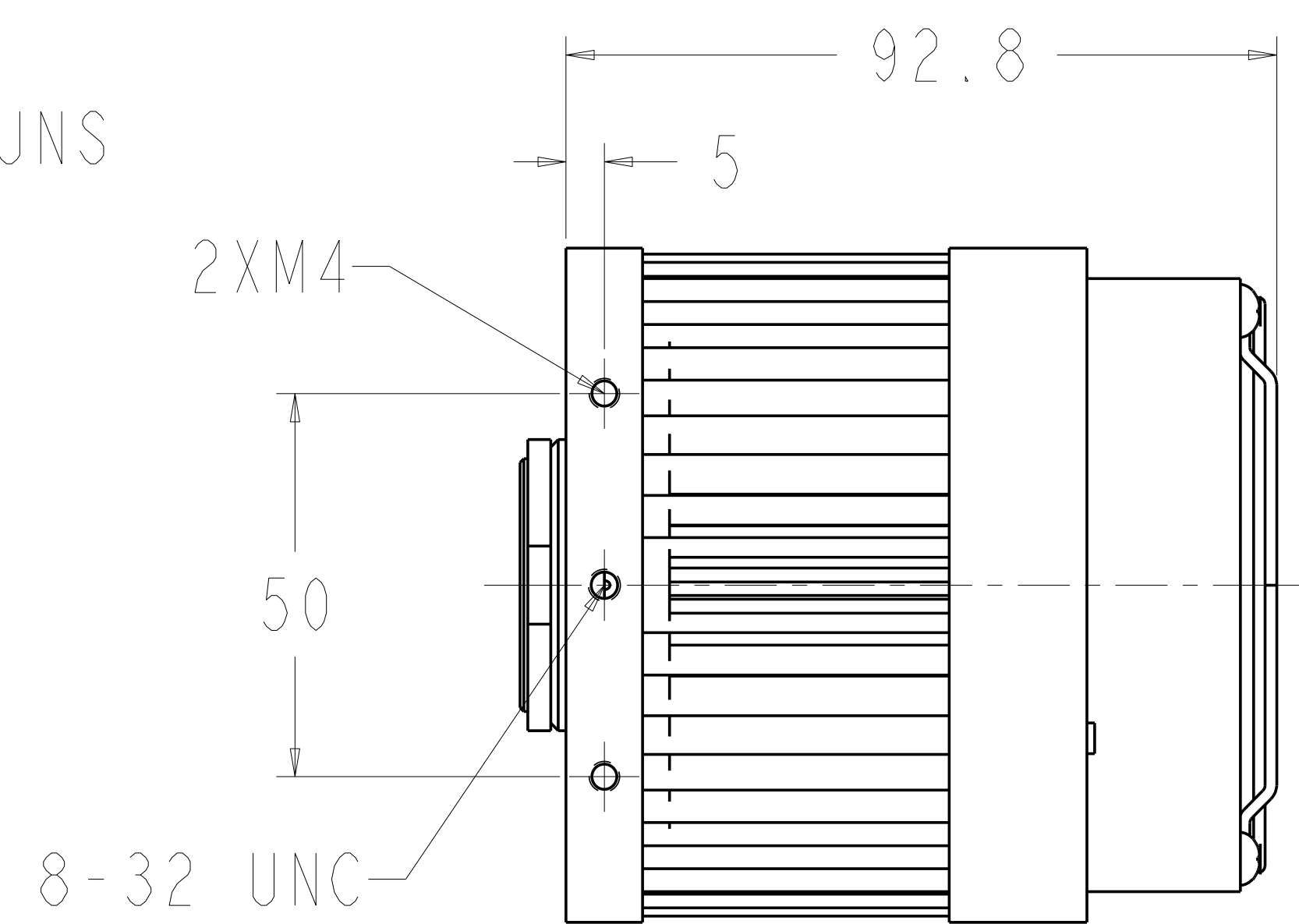
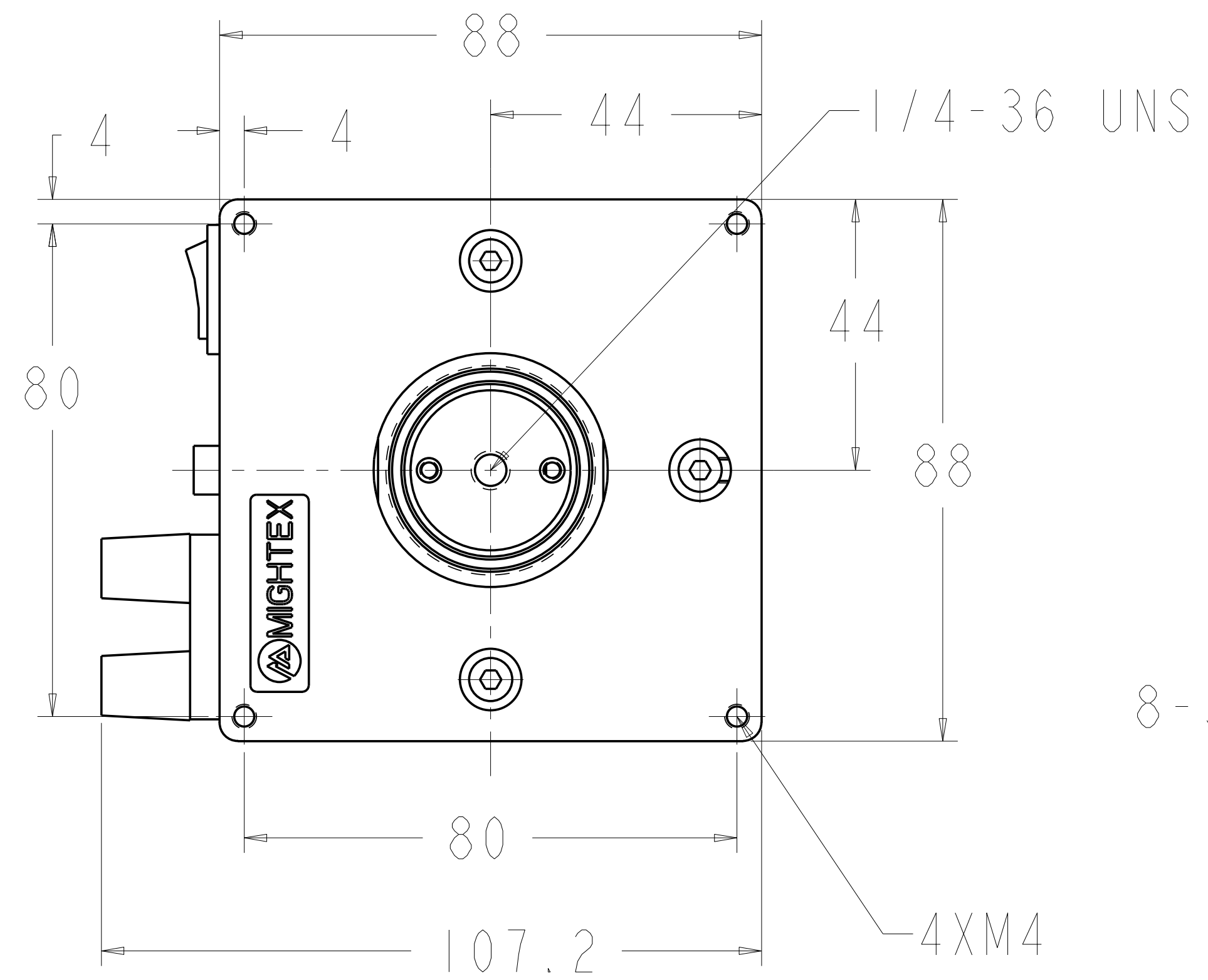
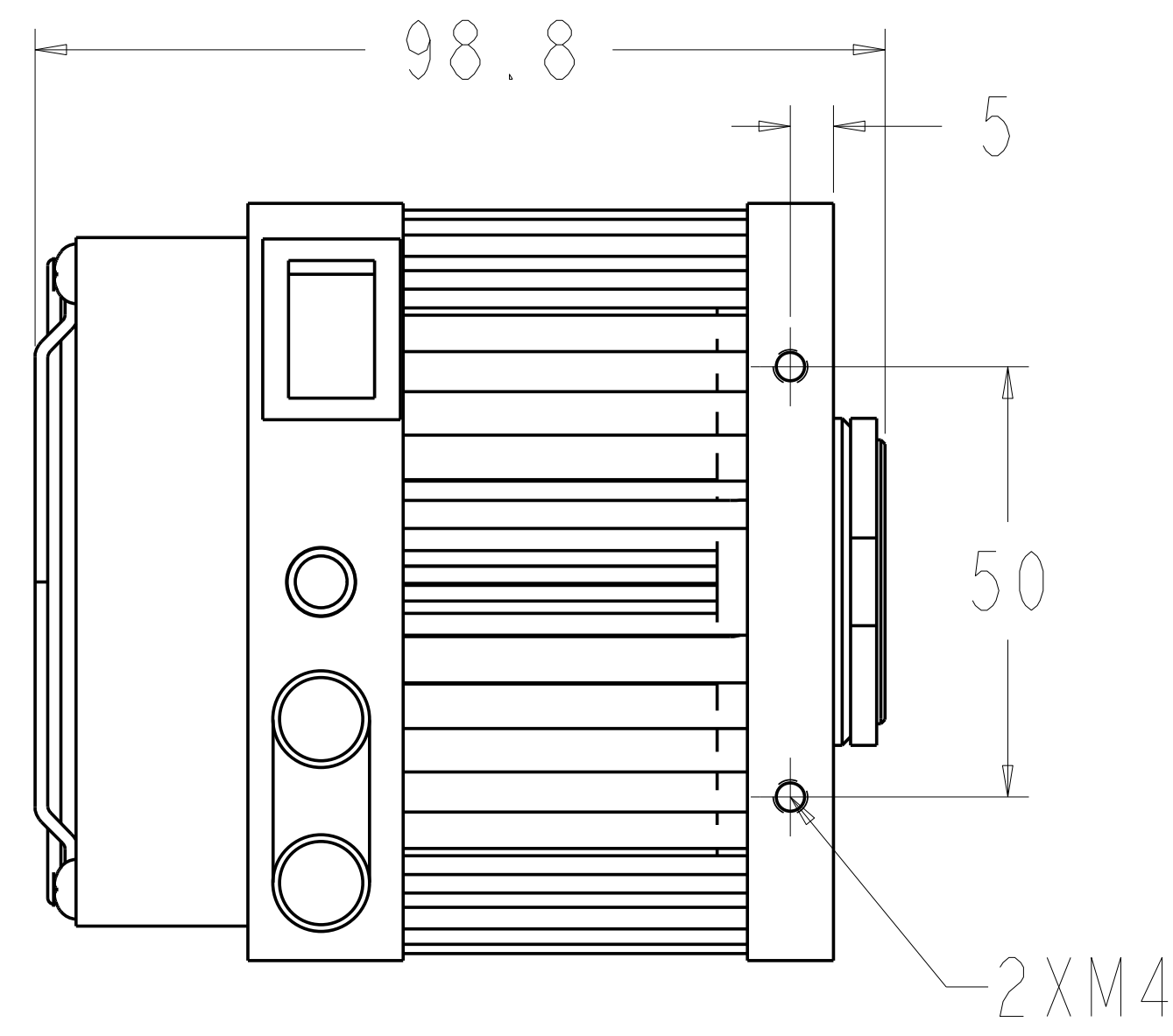

This document and the information and data contained herein are proprietary to and the exclusive property of Mightex Systems. This document and the information and data contained herein may not be used, copied, published or disclosed without the express prior written consent of Mightex Systems.

|                    |  |   |                  |                             |
|--------------------|--|---|------------------|-----------------------------|
| MATERIAL:          | THE INFORMATION AND DATA CONTAINED HEREIN CONFORMS TO<br><b>ASME Y14.5M-1994</b> | DRAWN:  | DATE: 10-Apr-14  | Mightex Systems             |
| ALT MATL:          | ALL UNTOLERANCED DIMENSIONS ARE<br><b>BASIC</b>                                  | EDGE/COR BREAK:                                   | RADII INSIDE:    |                             |
| CASE DEPTH:        | UNLESS OTHERWISE SPECIFIED,<br>ALL DIMENSIONS ARE IN<br><b>MM</b>                | RADII OUTSIDE:                                    | THIRD ANGLE PROJ | SIZE NO.<br><b>D</b> 176000 |
| HARDNESS:          |  | UNLESS OTHERWISE SPECIFIED:<br>6.3 SURFACE FINISH | PRO/ENGINEER*    |                             |
| SURFACE TREATMENT: |  |   |                  | REL NO. SHEET 1 OF 1        |